

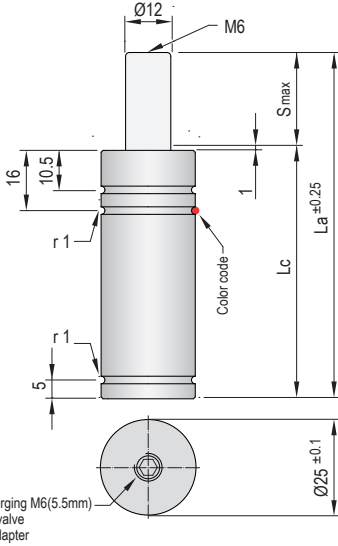

VDI SAFETY



**i** Pressure medium **Nitrogen (N<sub>2</sub>)**

Max. charging pressure	175 Bar
Min. charging pressure	25 Bar
Rod seal area	1,13 cm <sup>2</sup>
Operating temperature	0°C - 80°C
Force increase by temperature	0,33 %/°C
Max. stem speed	1,6 m/s
Maintenance kit	Kit G25



Maximum strokes / minute (at 20°C)

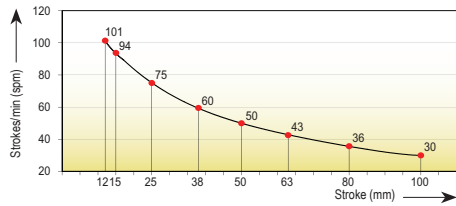

Code	Smax mm	La mm	Lc mm	V l	Kg
TPG 25x12	12	78	66	0,009	0,16
TPG 25x15	15	84	69	0,010	0,17
TPG 25x25	25	104	79	0,014	0,18
TPG 25x38	38	130	92	0,019	0,22
TPG 25x50	50	154	104	0,024	0,25
TPG 25x63	63	180	117	0,029	0,26
TPG 25x80	80	214	134	0,035	0,28
TPG 25x100	100	254	154	0,043	0,32

Color code	Fa daN	90% F daN	P Bar
GR (Green)	50 (±5)	≈ 70	45
BL (Blue)	100 (±10)	≈ 135	90
RD (Red)	150 (±15)	≈ 205	135
YW (Yellow)	200 (±20)	≈ 265	175
(Other forces)	28 - 200	≈ 40 - 277	25 - 175

The black color code denotes a different pressure from that which the customer could choose when ordering between the minimum charging pressure and the maximum charging pressure. If not otherwise specified, the gas spring will be supplied in the yellow code version (YW).

How to order

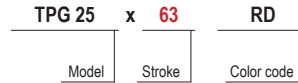

Force/stroke ratio

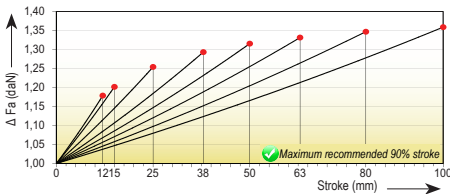

Initial force/charging pressure ratio

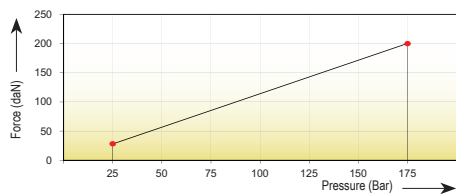

Assembly possibilities



Follow guidelines  
Page 287



DROP-IN



SCREWS

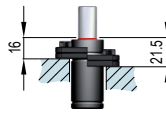

FS 25/1-FS 25/2

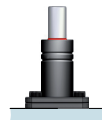

FS 25/1-FS 25/2

TPA  
TPG

TPCT

TPSL

STOP  
CYLINDER

STOP  
CYLINDER

TPSR

TPSR5

TPNS

TPHT

TPHT

TPHT

TPHT

TPHT

TPHT

TPHT

TPHT

TPHT

TPHT

TPHT

TPHT

TPHT

TPHT

TPHT

TPHT

TPHT

TPHT